



MARK III



3,000 to 6,000 # DBP

LOW PROFILE INDUSTRIAL TOW TRACTOR



Photo may show optional equipment

Trowin Industries, Inc.

737 Herbert St. | Chippewa Falls, WI 54729

715-738-1690 PH | 715-738-1693 FX

www.trowin.com

specifications



Mark III

3,000 to 6,000 lb DBP
Low Profile Industrial Tow Tractor



Engine: Ford LRG-425, 2.5 ltr. 4-cylinder EFI Industrial Gasoline Engine w/ Engine Shutdown Protection (*std*)
Cummins 3.3 ltr. 4-cylinder Diesel Engine, 65 hp (*optional*)
Ford ESG-642, 4.2 ltr. V-6 EFI Industrial Gasoline Engine, w/ Engine Shutdown Protection (*optional*)

Transmission: Ford A4LD Automatic Transmission, 2 Speed Forward & 1 Reverse (*std*)
Ford C-6 Automatic Transmission, 2 or 3 Speeds Forward & 1 Reverse (*w/ Cummins or V-6*)
Velvet Drive T72 Automatic Transmission, 1 Speed Forward & Reverse (*opt*)

Drive Axle: ArvinMeritor TA-267 Rigid Mount (*std*) Suspension Mount (*optional*)

Steer Axle: Heavy Duty Tubular Industrial Beam Mounted on Semi-elliptical Springs

Service Brakes: Four-wheel Disc, Power Assisted Split System

Parking Brake: Lever Operated, Drum Type on Output of Transmission

Electrical System: 12-Volt Negative Ground, 95-Amp Alternator, Keyed Anti-restart Ignition, Horn, Sealed Beam Headlights, Stop/Tail Lights & Back-up Lights (2ea)

Instrumentation: GAUGES: Engine Hour Meter, Water Temperature, Fuel level. WARNING LIGHTS: High Engine & Transmission Temperature, Low Oil Pressure, Charging System, Brake System Failure, Parking Brake Engaged.

Steering: Full-time, Power Assisted, Hydrostatic System with 14" wheel

Tires: Front: 185/70R14 Rear: 6.50-16 Single or Dual

Seat: Single Operator Metal Pan Seat with Vinyl Padding

Frame: Unitized Steel Construction, 1" Front/Rear Bumpers and Main Chassis Rails, 3/8 Body Panels, Media Blasted for Superior Paint Adhesion

Finish: Primer: 2-part Light Gray Epoxy Primer Finish: 2-part Polyurethane (White, Yellow or Orange)

Options: LPG, Diesel, Cab, Overhead Guard, Heater/Defroster, Back-up Alarm, Turn Signals, Tilt Steering, Suspension Seats, Couplers, Others Available

Weights:	DBP (lbs)(kg)	3,000(1360)	4,000(1820)	5,000(2270)	6,000(2720)
	GVW (lbs)(kg)	4,000(1814)	5,200(2360)	6,500(2950)	7,600(3450)

Towing Capacity is 10xs the DBP* GVW ± 5%

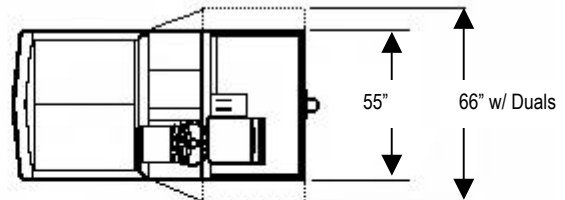
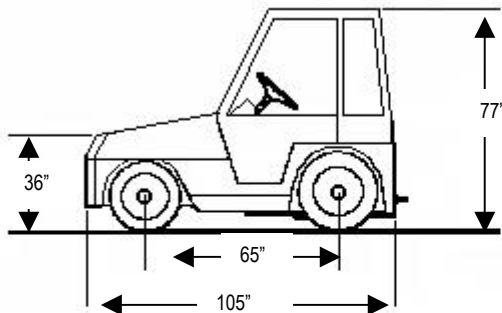

Specifications Subject to Change Without Notice