



MARK VII



40,000 to 60,000 # DBP

INDUSTRIAL TOW TRACTOR



LOW PROFILE PUSHBACK TRACTOR



Photo may show optional equipment

Trowin Industries, Inc.

737 Herbert St. | Chippewa Falls, WI 54729

715-738-1690 PH | 715-738-1693 FX

www.trowin.com

specifications



Mark VII

40,000 to 60,000 lb DBP
Industrial Tow Tractor & Pushback



Engine: Cummins 6BTA, 5.9 ltr. 6-Cylinder Turbo Diesel Engine, 185 hp (*std*)
Ford WSG-6.8 ltr. V-10 EFI Industrial Gasoline Engine, w/ Engine Shutdown Protection (*optional*)

Transmission: Funk 2000, 6 Speeds Forward & 3 Reverse (*std*)

Axles: Arvin Meritor Heavy Duty w/ Planetary Wheel Ends, Trunion Mount Rear, Fixed Front
Tow Tractor (*rear drive-std, 4-wheel drive-opt*)
Pushback (*4-wheel drive-std*)

Steering: Front-Wheel Full Time Hydrostatic Power Steering (*std*)
Electronically Controlled, 4-Wheel 3-Mode Selectable Steering (*Front, Crab, & Coordinated*)(*opt*)

Brakes: Service: Four-wheel Power Assisted Hydraulic Shoe Type
Parking: Lever Operated, Disc on Output of Transmission

Electrical System: 12-Volt Negative Ground, 95-Amp Alternator, Keyed Anti-restart Ignition, Horn, Sealed Beam Headlights, Stop/Tail Lights & Back-up Lights (2ea)

Instrumentation: GAUGES: Engine Hour Meter, Water Temperature, Fuel level. WARNING LIGHTS: High Engine & Transmission Temperature, Low Oil Pressure, Charging System, Brake System Failure, Parking Brake Engaged.

Tires: 40,000 DBP 385/65R22.5 50,000 DBP 425/65R22.5 60,000 DBP 445/65R22.5

Seat: Single Operator Metal Pan Seat with Vinyl Padding & Adjuster

Frame: Unitized Steel Construction, 4" Front & 14" Rear Bumpers, 2" Main Chassis Rails & Body Panels
Media Blasted for Superior Paint Adhesion

Finish: Primer: 2-part Light Gray Epoxy Primer Finish: 2-part Polyurethane (White, Yellow or Orange)(*std*)

Options: LPG, Diesel, Cab, Overhead Guard, Heater/Defroster, Back-up Alarm, Turn Signals, Tilt Steering, Suspension Seats, Couplers, Others Available

Weights:	DBP (lbs)(kg)	40,000(18145)	50,000(22680)	60,000(27215)
	GVW (lbs)(kg)	50,000(22680)	62,000(28122)	75,000(34020)

Towing Capacity is 10xs the DBP* GVW ± 5%

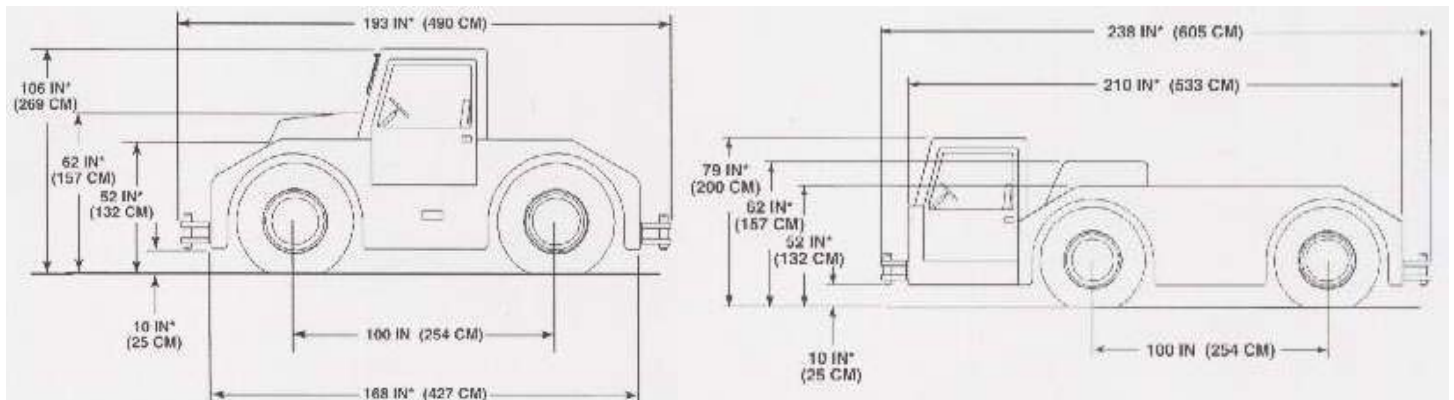

Both Units are 102" (259 CM) Wide

Specifications Subject to Change Without Notice