



# ST-4



2,000 to 6,000 # Capacity

## 4-Wheel Speed Truck



Photo may show optional equipment

# ***Trowin Industries, Inc.***

737 Herbert St. | Chippewa Falls, WI 54729

715-738-1690 PH | 715-738-1693 FX

[www.trowin.com](http://www.trowin.com)

specifications



# ST-4



## 2,000 to 6,000 lb Capacity 4-Wheel Industrial Speed Truck

**Engine:** Kohler 'Command Pro' 18 hp Air Cooled 2-Cylinder Gasoline Engine (*std*) 20hp LPG (*opt*)  
Ford 1.6 ltr. 4-Cylinder EFI Gasoline Engine, w/ Engine Shutdown Protection (*opt*)(*requires other options*)  
Ford 2.5 ltr. 4-Cylinder EFI Gasoline Engine w/ Engine Shutdown Protection (*opt*)(*requires other options*)  
6hp Continuous Duty Electric Motor; 24, 36, 48, 72, & 80 Volt (*opt* )( *requires other options*)

**Transmission:** Model 14 w/ Automatic Clutch, 1 Speed Forward & 1 Reverse  
T72 Automatic Transmission w/ Torque Converter, 1 Speed Forward & 1 Reverse (*opt*)(*requires other options*)  
Ford A4LD Automatic w/ Torque Converter, 2 Speeds Forward & 1 Reverse (*opt*)(*requires other options*)

**Drive Axle:** Heavy Duty Automotive Type, Rigid Mount (*std*)                      Suspension Mount (*optional*)

**Steer Axle:** Heavy Duty Tubular Industrial Beam Mounted on Semi-elliptical Springs

**Brakes:** Service: 4-Wheel Disc, Power Assisted Split System    Parking: Lever Operated, Disc on Rear Wheel

**Electrical System:** Kohler: 12-Volt Negative Ground, 25-Amp Alternator, Keyed Anti-restart Ignition, Horn  
Ford: 12-Volt Negative Ground, 95-Amp Alternator, Keyed Anti-restart Ignition, Horn  
Electric: Controller and Components Compatible w/ Selected Voltage

**Instrumentation:** Kohler: Volt Meter, Combination Hour/Tachometer/Maintainence Meter, Low Oil  
Ford: Engine Hour Meter, High Engine & Transmission Temperature, Low Oil Pressure, Charging System

**Steering:** Full-time, Power Assisted, Hydrostatic System with 14" wheel

**Tires:** 5.30 x 8 8 ply (*std*)                      5.30 x 12 8 ply (*opt*)

**Seat:** Single Operator Metal Pan Seat with Vinyl Padding

**Frame:** Unitized Welded Heavy Duty Steel Construction, 10" Outer Frame, 3/8" Inner Frame & Bumpers  
Media Blasted for Superior Paint Adhesion

**Finish:** Primer: 2-part Light Gray Epoxy Primer    Finish: 2-part Polyurethane (White, Yellow or Orange)

**Options:** LPG, Diesel, Cab, Overhead Guard, Heater/Defroster, Back-up Alarm, Turn Signals, Tilt Steering, Suspension Seats, Couplers, Others Available

Model #	ST-42	ST-43	ST-44	ST-45	ST-46
Capacity lbs(kg)	2,000(900)	3,000(1360)	4,000(1814)	5,000(2268)	6,000(2721)

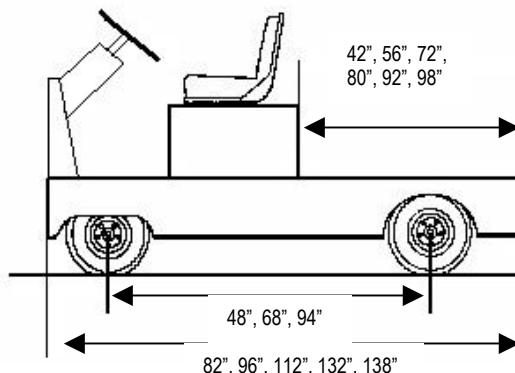
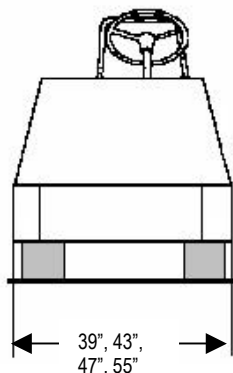

\*Certain Bed Lengths Require a Specific Wheel Base  
\*Custom Lengths & Widths Available  
\*Consult Dealer or Factory